

Volume escavado = 3,07m³
Volume reaterro = 1,04m³

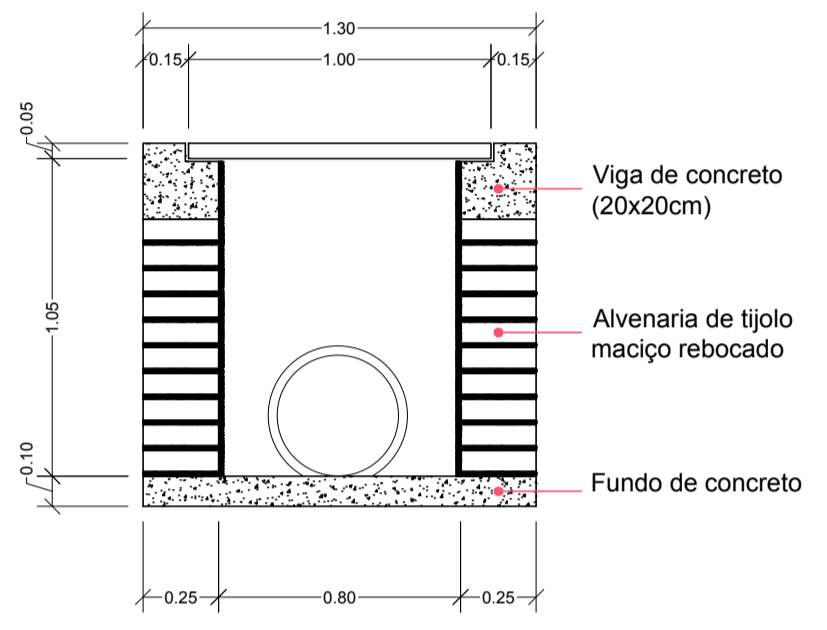

01 DETALHE DA CAIXA COLETORA 1
ESCALA 1:25

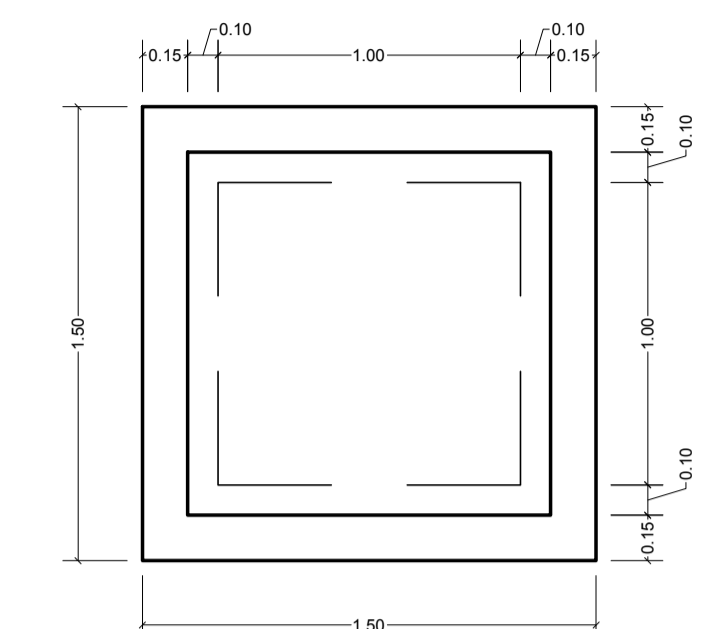

Volume escavado = 4,54m³
Volume reaterro = 1,39m³

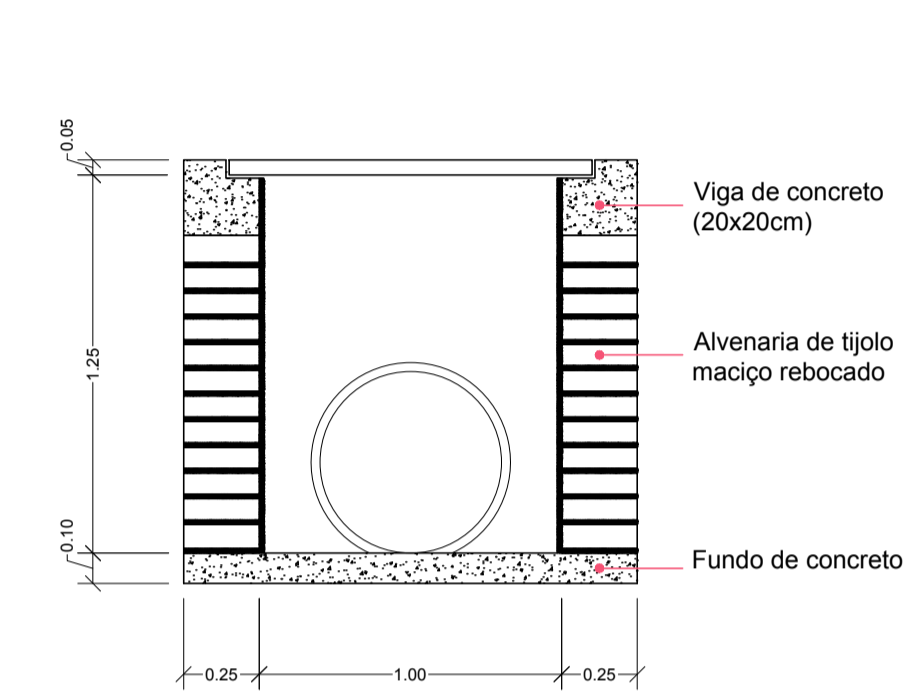

02 DETALHE DA CAIXA COLETORA 2
ESCALA 1:25

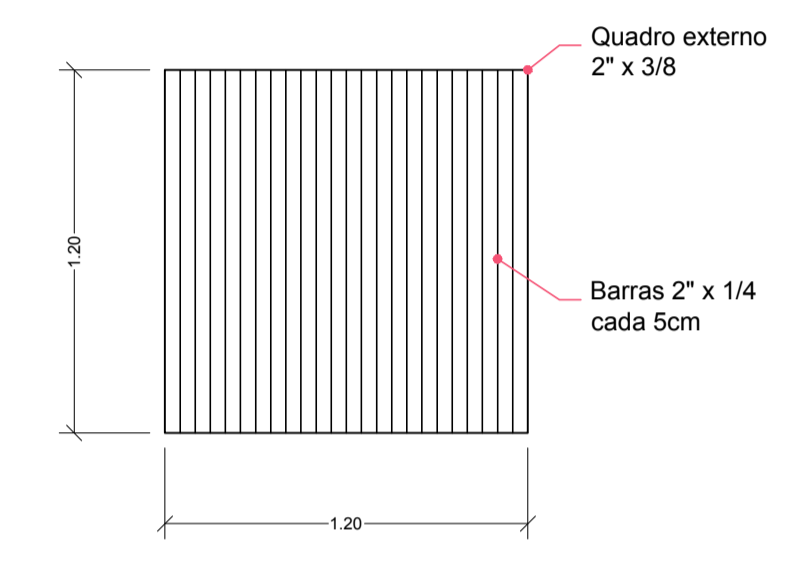

04 DETALHE DA ESCAVAÇÃO DAS VALAS
ESCALA 1:25

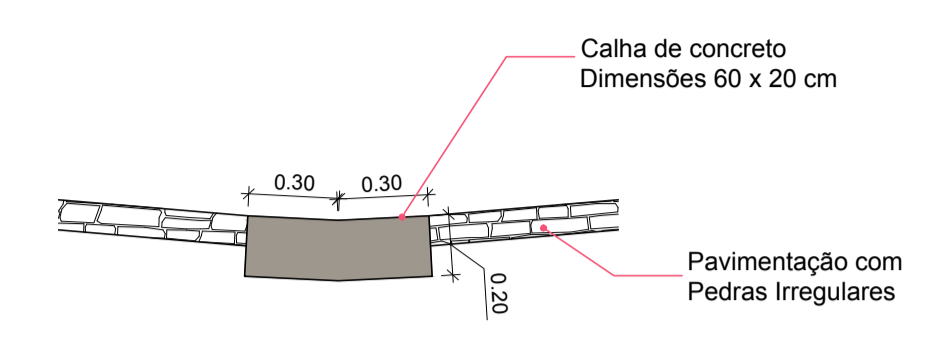
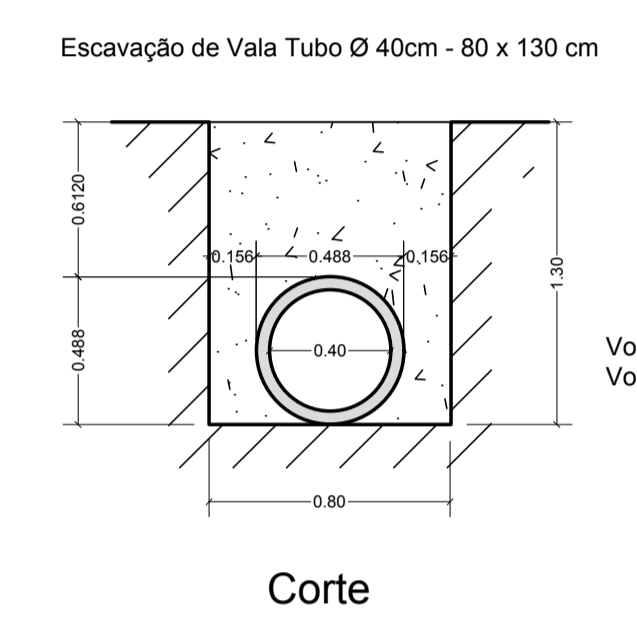

03 DETALHE DA CALHA
ESCALA 1:25

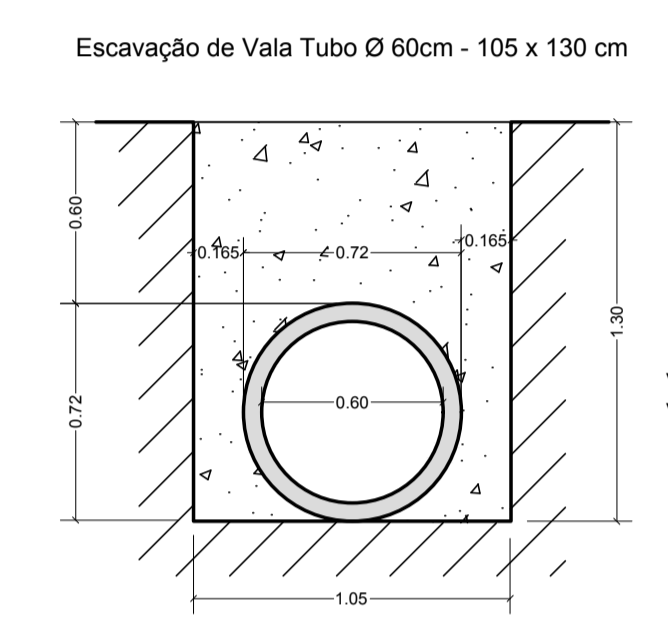

Volume escavado = 1,36m³
Volume reaterro = 0,95m³

Rua Venancio Aires

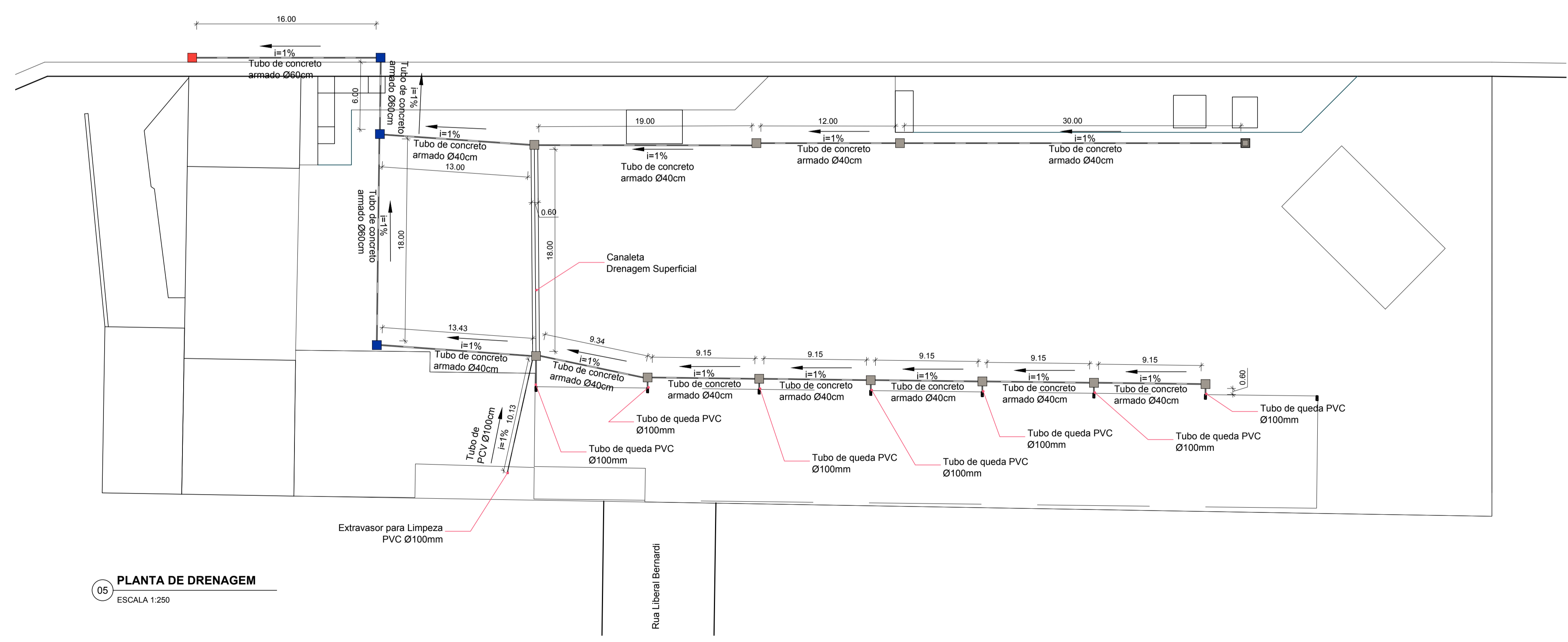

05 PLANTA DE DRENAGEM
ESCALA 1:250



Prancha	PV 02/04
Total de pranchas	20/27

Rua Independência 110 Sala 24 • Santo Augusto - RS • (51) 3781-1965 • email: eng.eugenio.frizzo@gmail.com

Conteúdo				
DRENAGEM				
Planta de Drenagem e Detalhes das Caixas de Captação				
Obra	AMPLIAÇÃO E REFORMA DA SEDE DA SECRETARIA DE OBRAS			
Proprietário	Município de Augusto Pestana			
Endereço	Rua Venâncio Aires, 2712 Augusto Pestana - RS			
Resp. Téc.	Eng. Civil Eugenio Frizzo (CREA-RS 07.544-D) Arq. e Urb. Leonardo Postay Frizzo (CAU/A-107991-3) Arq. e Urb. Bibiana S. M. da Rocha (CAU/A-101076-D)			
Escala	Área	Data	Desenho	Versão
Indicadas	3.301,45 m²	Agosto/2016	Sandro	1-10/08

Legenda

	Caixa coletora 1
	Caixa coletora 2
	Caixa existente