

Relação do aço

AÇO	N	DIAM (mm)	QUANT	C.UNIT (cm)	C.TOTAL (cm)
CA60	1	5.0	36	76	2736
	2	5.0	18	72	1296
	3	5.0	14	102	1428
	4	5.0	46	96	4416
CA50	5	6.3	72	110	7920
	6	10.0	16	162	2592
	7	10.0	8	121	968
	8	10.0	2	70	140
	9	10.0	2	133	266
	10	10.0	2	117	234
	11	10.0	2	172	344
	12	10.0	4	523	2092
	13	10.0	4	257	1028
	14	10.0	4	279	1116
	15	10.0	2	132	264
	16	10.0	2	195	390

AÇO	DIAM (mm)	C.TOTAL (m)	QUANT + 10 % (Barras)	PESO + 10 % (kg)
CA50	6.3	79.2	8	21.3
	10.0	94.4	9	64
CA60	5.0	98.8	10	16.7
PESO TOTAL (kg)				
CA50			85.3	
CA60			16.7	

Volume de concreto (C-25) = 2.06 m³
Área de forma = 23.31 m²

VB6 (12 x 40)
Esc.: 1:50

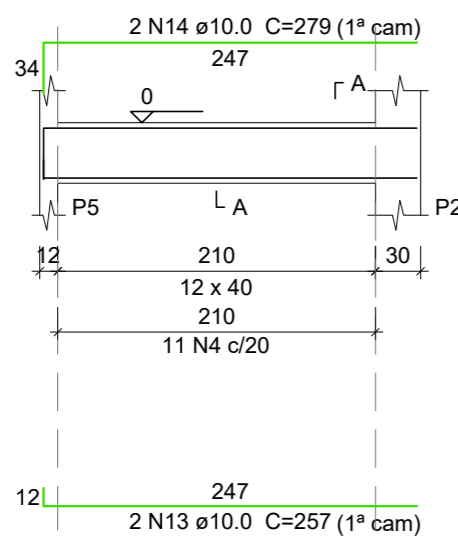

SEÇÃO A-A
Esc.: 1:25

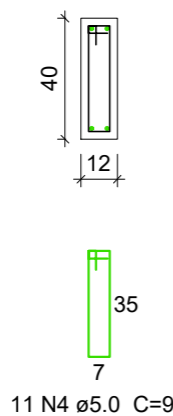

VB1 (15 x 40)
Esc.: 1:50

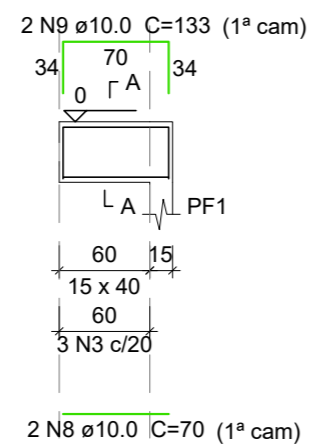

SEÇÃO A-A
Esc.: 1:25

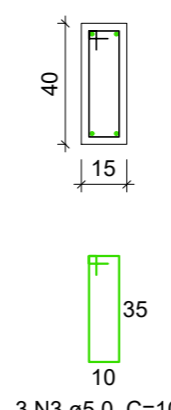

VB2 (15 x 40)
Esc.: 1:50

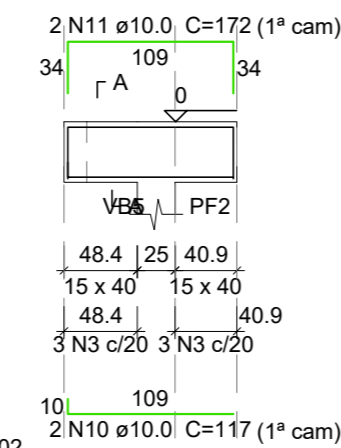

SEÇÃO A-A
Esc.: 1:25

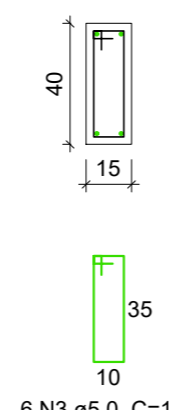

VB3 (12 x 40)
Esc.: 1:50

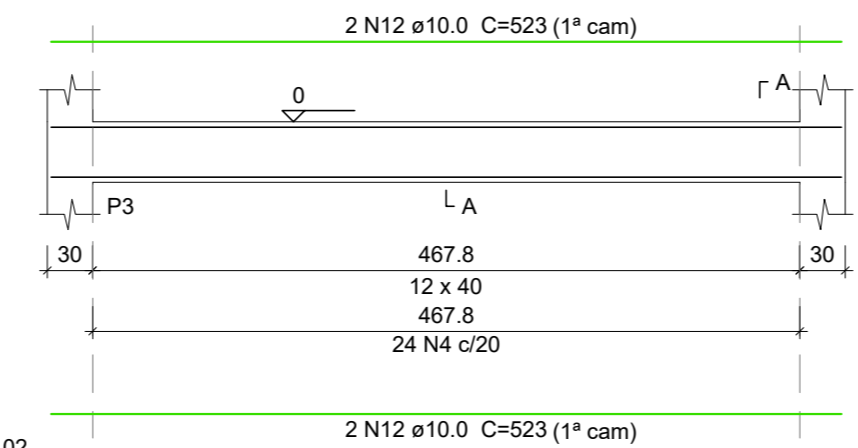

SEÇÃO A-A
Esc.: 1:25

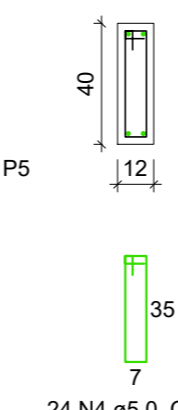

VB4 (12 x 40)
Esc.: 1:50

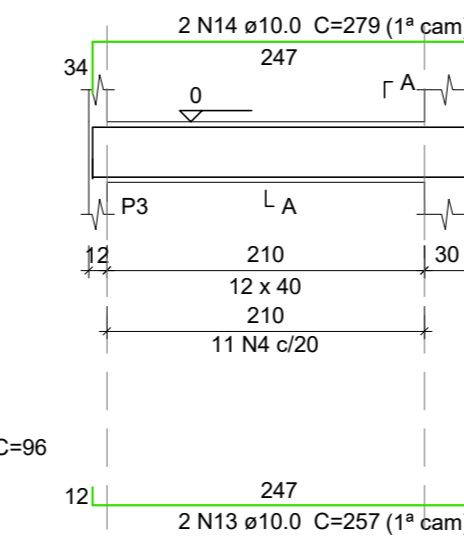

SEÇÃO A-A
Esc.: 1:25

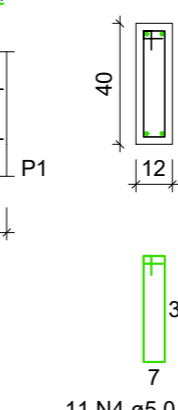

VB5 (15 x 40)
Esc.: 1:50

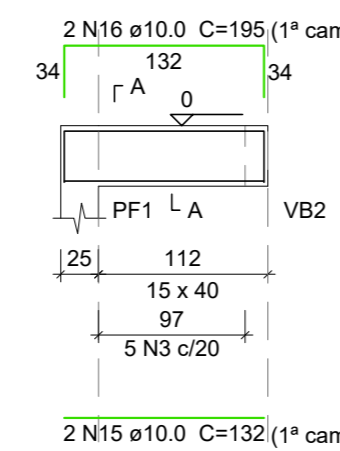

SEÇÃO A-A
Esc.: 1:25

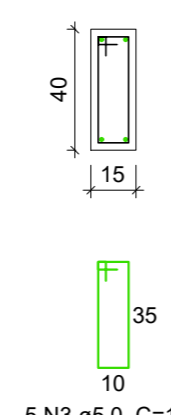

S1=S2=S3=S5=SF1=SF2
PLANTA
Esc.: 1:50

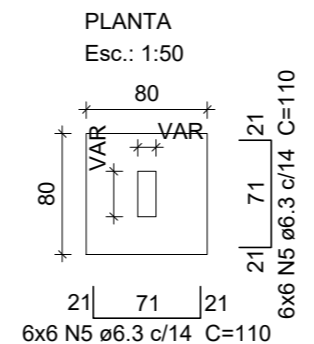

CORTE
Esc.: 1:25

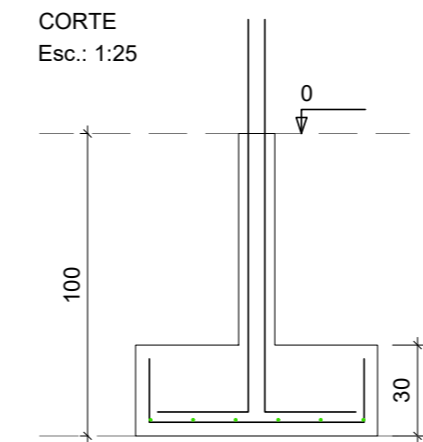

P1=P2=P3=P5
BALDRAME - L1

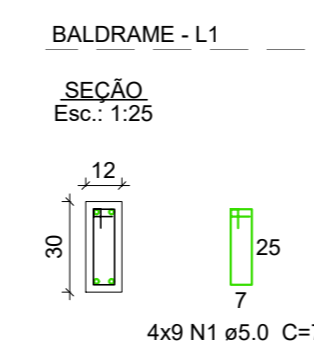

PF1=PF2
BALDRAME - L1



TABELA FCK DA OBRA

Sapatas	25 mpa
Vigas, Lajes e Pilares	25 mpa
abatimento (slump)	10 +- 2cm

REV.	DESCRIÇÃO	DATA	RESP.
01	LIBERADO PARA EXECUÇÃO	FEV/2022	João N.
00	ENVIADO PARA REVISÃO PREFEITURA	DEZ/2021	João N.

PROPRIETÁRIO:
Prefeitura Municipal de Augusto Pestana

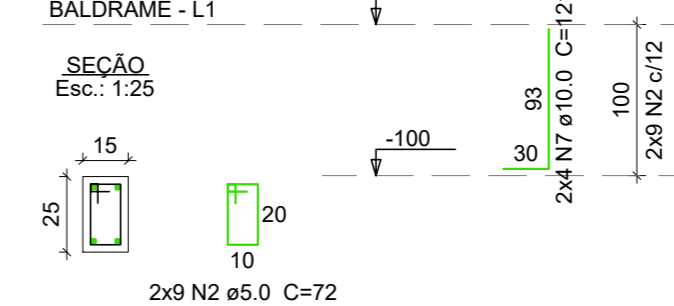
RESPONSÁVEIS TÉCNICOS:

JOÃO DA JORNADA FORTES FILHO
Arquiteto e Urbanista CAU A 52.256-2

MARIANA DA SILVA FERREIRA FORTES
Arquiteta e Urbanista CAU A 64.319-0

JOÃO DA JORNADA FORTES NETO
Engenheiro Civil CREA RS 214.992

ENDEREÇO: Estrada Rural
BAIRRO: Marmeleiro
SETOR URBANO: Interior
CIDADE / UF: Augusto Pestana / RS
QUADRA: ---
LOTE: ---

ÁREA A EDIFICAR: ---
CONJUNTO N°: 1
PRANCHA N°: 2/3
ÁREA DO LOTE: ---
DATA: FEV/22