

ARMAÇÃO POSITIVA DAS LAJES

Esc.: 1:50

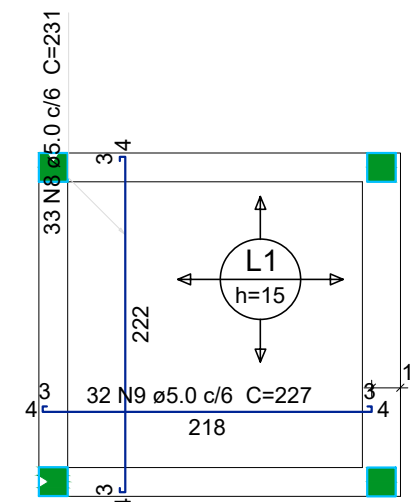

ARMAÇÃO NEGATIVA DAS LAJES

Esc.: 1:50

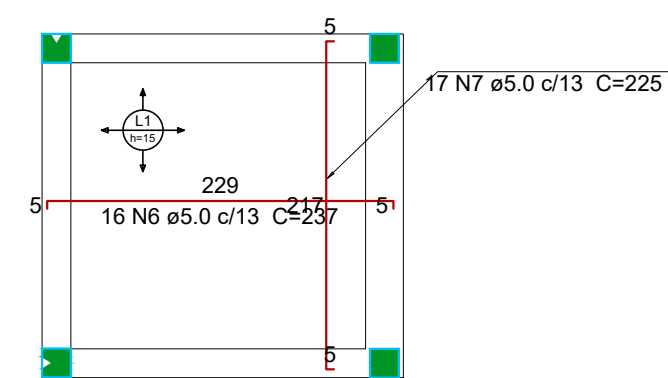

Relação do aço

AÇO	N	DIAM (mm)	QUANT	C.UNIT (cm)	C.TOTAL (cm)
Negativos Positivos VC3	1	5.0	189	68	12852
	2	5.0	27	90	2430
	3	5.0	65	110	7150
	4	5.0	15	122	1830
	5	5.0	24	102	2448
	6	5.0	16	237	3792
	7	5.0	17	225	3825
	8	5.0	33	231	7623
	9	5.0	32	227	7264
	10	6.3	4	535	2140
	11	10.0	32	317	10144
	12	10.0	4	477	1908
	13	10.0	4	588	2352
	14	10.0	2	241	482
	15	10.0	2	285	570
	16	10.0	2	525	1050
	17	12.5	2	421	842
	18	12.5	2	414	828
	19	12.5	2	549	1098

Resumo do aço

AÇO	DIAM (mm)	C.TOTAL (m)	QUANT + 10 % (Barras)	PESO + 10 % (kg)
CA50	6.3	21.4	2	5.8
	10.0	165.1	16	111.9
	12.5	27.7	3	29.3
CA60	5.0	492.2	46	83.4
PESO TOTAL (kg)				
CA50			147	
CA60			83.4	

Volume de concreto (C-25) = 3.13 m³
Área de forma = 44.81 m²

VC1 (19 x 40)

Esc.: 1:50

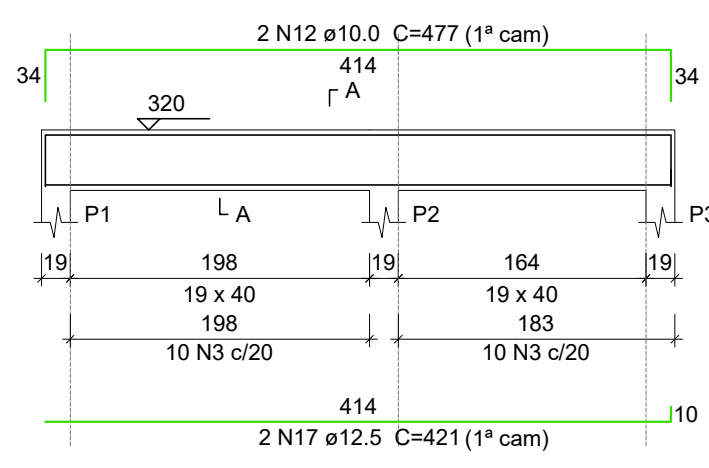

SEÇÃO A-A

Esc.: 1:25

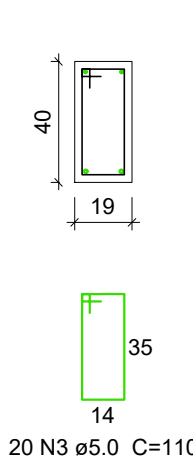

VC2 (19 x 40)

Esc.: 1:50

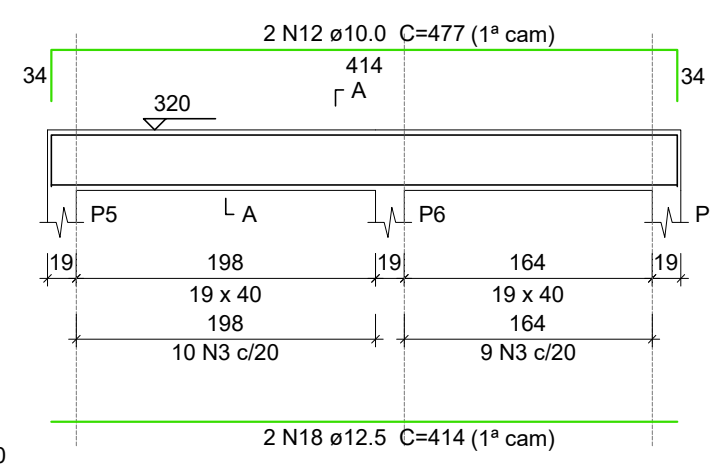

SEÇÃO A-A

Esc.: 1:25

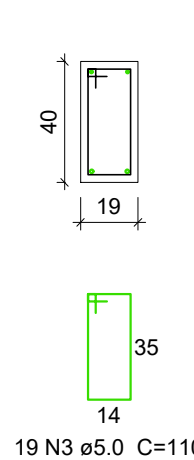

VC3 (19 x 40)

Esc.: 1:50

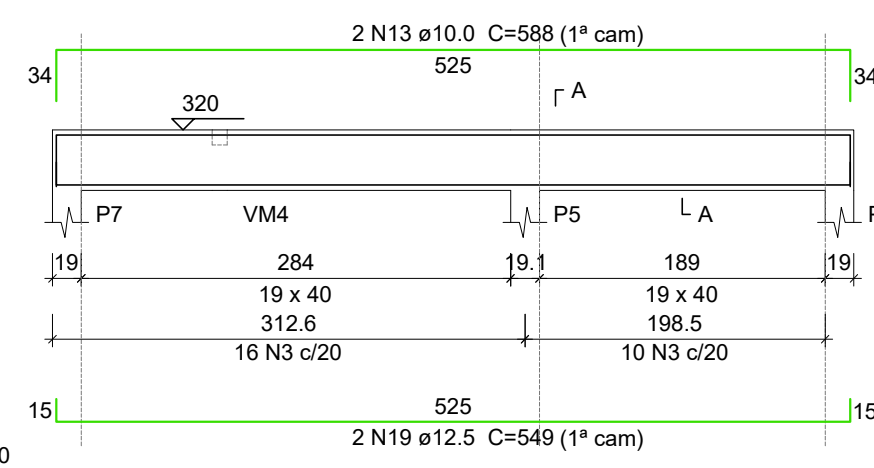

SEÇÃO A-A

Esc.: 1:25

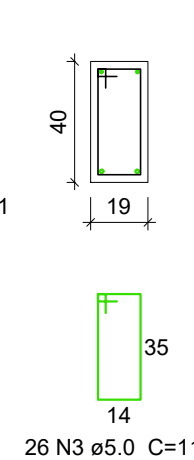

VC4 (25 x 40)

Esc.: 1:50

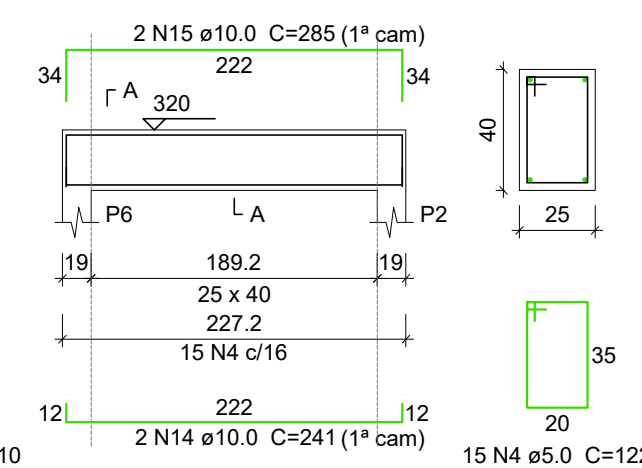

SEÇÃO A-A

Esc.: 1:25

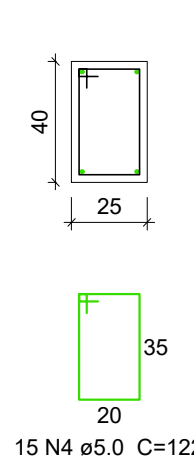

VC5 (15 x 40)

Esc.: 1:50

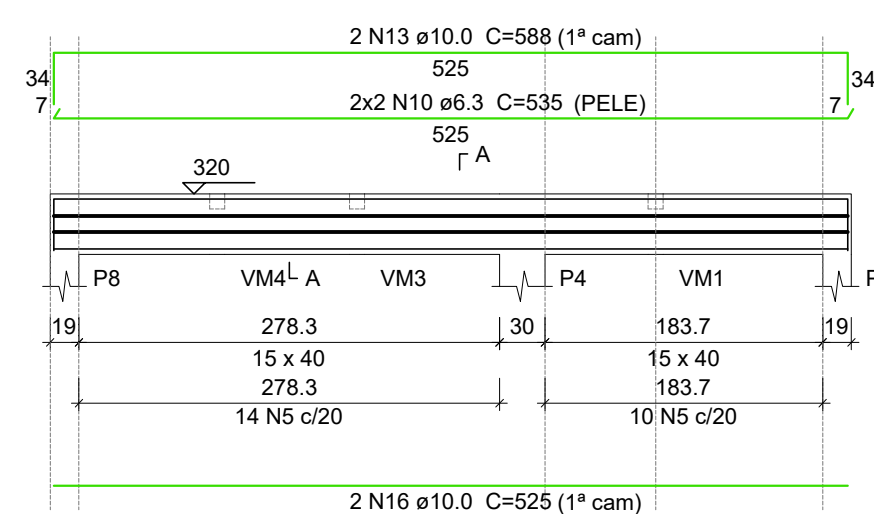

SEÇÃO A-A

Esc.: 1:25

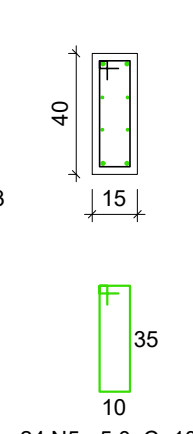

P1=P2=P3=P5=P6=P7=P8

COBERTURA - L2

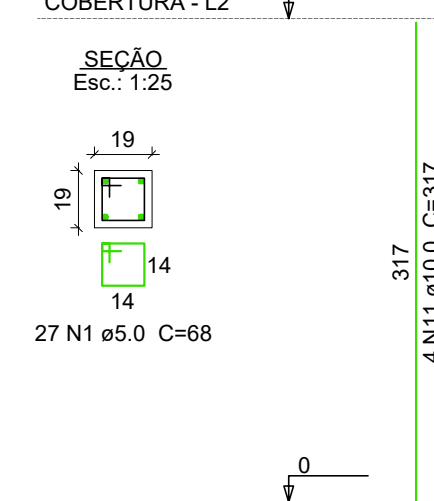

SEÇÃO

Esc.: 1:25

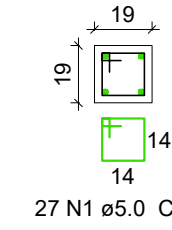

P4

COBERTURA - L2

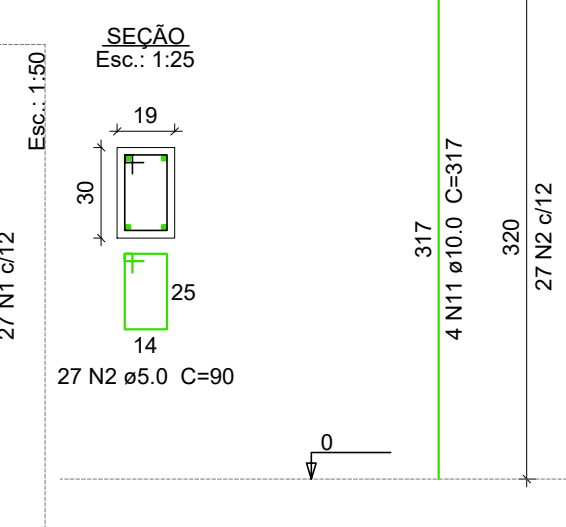

SEÇÃO

Esc.: 1:25



TABELA FCX DA OBRA

Sapatas	25 mpa
Vigas, Lajes e Pilares	25 mpa
abatimento (slump)	10 +/- 2cm

REV.	DESCRIÇÃO	DATA	RESP.
01	LIBERADO PARA EXECUÇÃO	FEV/2022	João N.
00	ENVIADO PARA REVISÃO PREFEITURA	DEZ/2021	João N.

PROPRIETÁRIO: Prefeitura Municipal de Augusto Pestana

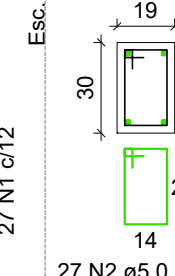
RESPONSÁVEIS TÉCNICOS: JOÃO DA JORNADA FORTES FILHO (Arquiteto e Urbanista CAU A 52.256-2)

MARIANA DA SILVA FERREIRA FORTES (Arquiteta e Urbanista CAU A 64.319-0)

JOÃO DA JORNADA FORTES NETO (Engenheiro Civil CREA RS 214.992)

ENDEREÇO: Estrada Rural, Marmeleiro
CIDADE / UF: Augusto Pestana / RS
SETOR URBANO: Interior
QUADRA: ---
LOTE: ---

ÁREA A EDIFICAR: ---
CONJUNTO N°: 1
PRANCHA N°: 5/5
ÁREA DO LOTE: ---
DATA: FEV/22

FORTES ARQUITETURA E ENGENHARIA

OBRA NÚMERO: 989

ESTRUTURAL COBERTURAS
PILARES, VIGAS E LAJES